

SPOT-N-TOW™ INSTALLATION INSTRUCTIONS - HONDA

Tools Required

- 1- 13-MM wrench
- 1- 14-MM wrench
- 2- 17-MM wrenches
- 2- 3/8" wrenches
- 2- 9/16" wrenches
- 1- 5-MM Allen wrench
- 1- 1/8" Allen wrench
- Marker
- Electric Drill
- 3/8" drill bit

Parts

- T-handle
- Outside housing
- Top bracket with 1 red dot
- Bottom bracket with 2 red dots
- Angle adapter
- Bottom brace installed in outside housing

Package of fasteners - Includes -

- | | |
|----------------------------|------------------------|
| 2 - SS threaded studs | 4 - SS Black cap nuts |
| 2 - 10-MM bolts | 2 - 10-MM SS lock nuts |
| 2 - 8-MM button head bolts | 2 - 8-MM SS lock nuts |
| 2 - 3/8 x 1-1/4" bolts | 2 - 3/8" lock nuts |
| 2 - 3/8" washers | 1 - Foam Gasket |

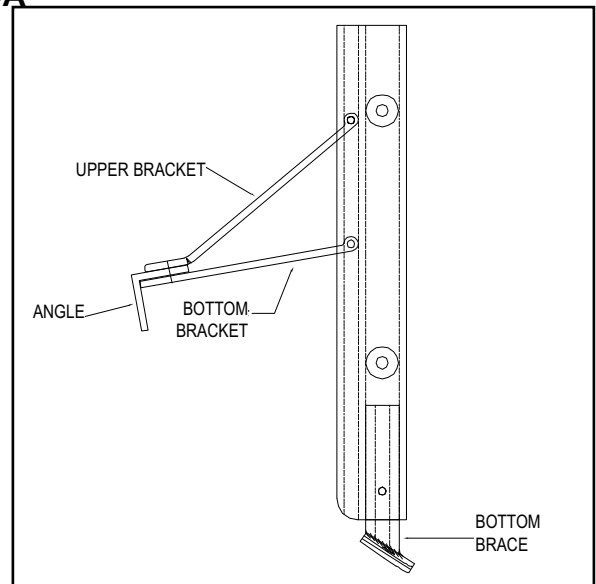

Preparation & Installation

1. Install top bracket in outside housing with red dot down from T-handle. Line up with top hole in housing and install SS threaded stud with 2 black cap nuts.
2. Install the bottom bracket with two red dots up in the channel from the bottom of outside housing. Align holes and install SS threaded stud with nuts.
3. Install the angle-adapter, with the two 8-MM x 25-MM button head bolts. One dot to one dot and two dots to two dots. Install 8-MM locking nuts and securely tighten.
4. Push T-handle lock button in with index finger and pull up on T-handle until it locks in top hole. Push button in again and remove it from unit completely.
5. Remove rear seat and compartment liner to expose factory ski eyebolt nuts.
6. Remove the two 13-MM nuts; be careful not to drop them or the lock washers.
7. Still holding the ski eye in from the outside, so it doesn't fall out, remove the grease Zerk bracket and the stress plate, now remove the factory ski eye.
8. Take the pre-assembled SPOT-N-TOW™ without the T-handle in it, install the SPOT-N-TOW™ from the bottom through the opening in the rear handle. Install the two 10-MM bolts that are provided with the SPOT-N-TOW™ through the brackets into the watercraft ski eyeholes.
9. Install the factory nut for alignment purposes only.
10. Mark holes in bottom brace or use brace for a temporary plate. Drill through the fiberglass hull, being careful to drill just through the fiberglass.
11. Install 9/16" bolts, locknuts, washers and gaskets through bottom brace.
12. Remove the factory nuts. Install the stress plate, grease Zerk bracket with the 2- 10MM lock nuts provided.
13. Re-align all nuts and bolts and re tighten
14. Slightly tighten the two-nylon anti-rattle set screws with the 1/8" Allen wrench. Handle should move up and down with slight drag.

Maintenance

- If using in salt water, be sure to rinse well after use. Push button and remove T-handle from outside housing. Rinse the button area well to prevent the button from sticking. Push button several times making sure that there are no salt particles left on the button prior to reassembly.
- Periodically check that all fasteners are tight, retighten if necessary.

How To Use

When sitting backward on the watercraft, reach around the bottom of the SPOT-N-TOW™. With your left hand, using the tip of your index finger, push the button that is in the bottom lock button hole.

Now pull up on the T-handle with your right hand until it locks in the up position.

To lower, use the same process on the top lock button hole. The key is not to put pressure on the T-handle until the button is totally pushed in.

Limited Warranty

Dock Edge + Inc. warrants this product to be free of defects in workmanship and material under normal conditions and for which it is intended for one (1) year from the date of purchase. Any defective product must be returned with a Return Goods Authorization #. A copy of the original sales receipt, must accompany all claims. The freight on the defective goods is the responsibility of the consumer.

Visit www.dockedge.com for further warranty details.