

Tools Required

- 1- 10-MM wrench
- 2- 9/16" wrenches
- 2- 3/8" wrenches
- 1- 4-MM Allen wrench
- 1- 1/8" Allen wrench
- Marker
- Electric Drill
- 3/8" drill bit

Parts

- T-handle
- Outside housing
- Top bracket with dot
- Bottom brace

Package of fasteners - Includes -

- 2 - SS threaded studs
- 4 - SS Black cap nuts
- 4 - 3/8" SS bolts
- 4 - 3/8" SS washers
- 4 - 3/8" SS lock nuts
- 1 - Foam Gasket

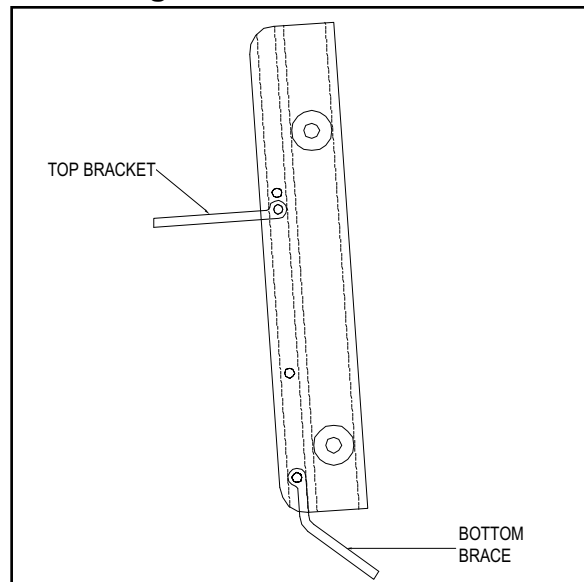

Preparation & Installation

1. Remove seat and storage liner.
2. Remove Ski-eye with metric wrenches.
(On some models you will need to remove or compress down some of the cross over tubes to get better access to the nuts and washers.)
3. Drill Ski Eye bracket holes in hull to 3/8" diameter with drill. (Be careful not to drill deeper than through the Fiberglass)
4. Install new upper bracket with 3/8" x 16 x 1-1/4" bolts, washers and lock nuts. Make sure bracket is installed with red dot up.
5. Slide the outside housing of the SPOT-N-TOW™ part way down over the top bracket you just installed, now slide bottom brace into the outside housing to the third hole from the bottom. (see drawing above) and install the threaded stud.(do not tighten at this time)
6. Line up top bracket cross-hole in the second hole from the top and install the threaded stud (do not tighten at this time)
7. Position and align unit so Bottom Brace makes solid contact with hull and mark for drilling.
8. Remove unit and drill the hull with a 3/8-inch drill bit. (Be careful not to drill deeper than through the Fiberglass). Reinstall unit as above. Install foam gasket between hull and bottom bracket. Install the 3/8" x 16 x 1-1/4" inch bolts, washers and lock nuts (leave loose to make sure it is lined up.)
10. Once everything is lined up tighten all bolts and nuts.
11. Reinstall storage liner and seat.
12. Slightly tighten the two nylon anti-rattle set screws with the 1/8 inch Allen wrench.
Handle should move up and down with slight drag.
13. Retighten all fasteners after first use.

Maintenance

- If using in salt water, be sure to rinse well after use. Push button and remove T-handle from outside housing. Rinse the button area well to prevent the button from sticking. Push button several times making sure that there are no salt particles left on the button prior to reassembly.
- Periodically check that all fasteners are tight, retighten if necessary.

How To Use

When sitting backward on the watercraft, reach around the bottom of the SPOT-N-TOW™. With your left hand, using the tip of your index finger, push the button that is in the bottom lock button hole.

Now pull up on the T-handle with your right hand until it locks in the up position.

To lower, use the same process on the top lock button hole. The key is not to put pressure on the T-handle until the button is totally pushed in.

Limited Warranty

Dock Edge + Inc. warrants this product to be free of defects in workmanship and material under normal conditions and for which it is intended for one (1) year from the date of purchase. Any defective product must be returned with a Return Goods Authorization #. A copy of the original sales receipt, must accompany all claims. The freight on the defective goods is the responsibility of the consumer.

Visit www.dockedge.com for further warranty details.