

Tools Required

- 1- Ratchet wrench
- 1- Ratchet wrench extension
- 1- 13-MM socket
- 2- 9/16" wrenches
- 2- 3/8" wrenches
- 1- 1/8" Allen wrench
- Marker
- Electric Drill
- 3/8" drill bit

Parts

- T-handle
- Outside housing
- Top bracket with 1 red dot
- Bottom bracket with 2 red dots
- Bottom brace

Package of fasteners - Includes -

- 2 - SS threaded studs
- 4 - SS Black cap nuts
- 2 - 1-1/4" x 3/8" SS Bolts
- 2- 3/8" SS Lock Nuts
- 2- 3/8" SS washers
- 1- Foam Gasket

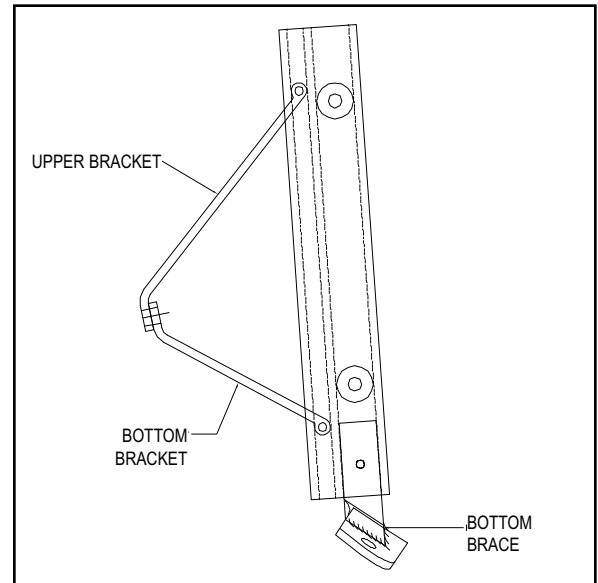
**Preparation & Installation**

1. Remove back seat and storage liner.
 2. Unbolt factory ski eye U-clamp with 13-MM socket wrench.
 3. Remove U-clamp/hook assembly; keep U-clamp, nuts and factory gasket for later assembly disregarding the hook.
 4. Remove T-handle by pushing the lock button again when T-handle is in top hole.
 5. Assemble SPOT-N-TOW™ brackets in outside housing, with stainless steel studs; the long bracket with one dot goes in top hole (see drawing above). The short bracket with two dots goes in the bottom hole. The large bracket goes behind the short bracket where the two meet to form a V, matching the red dots.
 6. Install the U clamp in bracket holes and line up U clamp, bottom bracket, top bracket, and factory gasket.
 7. Slide assembled unit up from the bottom of grab bar, locating it between the openings of the grab bar.
 8. Reinstall U clamp into original holes. Reinstall nuts and washers, tighten slightly for alignment purposes.
 9. Position and align bottom brace on hull. Mark holes for drilling. Remove pylon and drill 3/8" holes for bottom brace. Be sure to drill just through the fiberglass.
 10. Reinstall unit, with factory gasket, U clamps, washers and locking nuts. In bottom brace, install foam gasket between hull and brace. Insert the two 1-1/4" x 16 x 3/8" bolts, washers and locking nuts.
 11. Tighten all nuts and bolts.
 12. Reinstall T-handle.
 13. Slightly tighten the two nylon anti-rattle set screws with the 1/8" Allen wrench. Handle should move up and down with slight drag, re-tighten as necessary.
 15. Tighten all nuts and bolts after first use.
- Note: When opening the seat storage area it will be easier to raise the T-handle to its uppermost position, push button again and remove T-handle. After storage area is open, reinstall T-handle.

Maintenance

- If using in salt water, be sure to rinse well after use. Push button and remove T-handle from outside housing. Rinse the button area well to prevent the button from sticking. Push button several times making sure that there are no salt particles left on the button prior to reassembly.
- Periodically check that all fasteners are tight, retighten if necessary.

How To Use

When sitting backward on the watercraft, reach around the bottom of the SPOT-N-TOW™. With your left hand, using the tip of your index finger, push the button that is in the bottom lock button hole.

Now pull up on the T-handle with your right hand until it locks in the up position.

To lower, use the same process on the top lock button hole. The key is not to put pressure on the T-handle until the button is totally pushed in.

Limited Warranty

Dock Edge + Inc. warrants this product to be free of defects in workmanship and material under normal conditions and for which it is intended for one (1) year from the date of purchase. Any defective product must be returned with a Return Goods Authorization #. A copy of the original sales receipt, must accompany all claims. The freight on the defective goods is the responsibility of the consumer.

Visit www.dockedge.com for further warranty details.