

# SPOT-N-TOW™ INSTALLATION INSTRUCTIONS - SHPK

# 40-402-F

## Tools Required

- 1- 13-MM Socket
- 1- Socket wrench
- 1- Ratchet extension
- 2- 9/16" wrenches
- 2- 3/8" wrenches
- Marker
- Electric Drill
- 3/8" Drill Bit

## Parts

- T-handle
- Outside housing
- Top bracket assembled to angle
- Bottom brace pre-installed

## Package of fasteners - Includes -

- 1 - SS threaded stud
- 2 - SS Black cap nuts
- 2 - 8-MM washers
- 2 - 8-MM lock nuts
- 2 - 8-MM x 30-MM bolts
- 2 - 1-1/4" x 3/8" SS bolts
- 2 - 3/8" SS washers
- 2 - 3/8" SS lock nuts

## Preparation & Installation

1. Remove seat
2. Unbolt factory ski eye U-clamp with 13mm socket wrench
3. Remove T handle by pushing the lock button again when T handle is in top hole.
4. Install the angle bracket that is pre-assembled to the top bracket with the red dot down, with 8mm bolts into the ski-eye holes in the hull and tighten.
5. On this model the Spot-N-Tow goes on the outside of the rear grab bar. Slide the Outside Housing on to the ears of the top bracket from the top of housing. Line up the holes in the bracket to the top holes in housing and place threaded stud through these holes.
6. Push the pre-assembled bottom brace in until it makes contact with hull. Mark for drilling.
7. Remove pylon and drill 3/8" holes for the bottom brace. Be sure to drill just through the fiberglass only.
8. Reinstall unit, install bottom brace with foam gasket between hull and brace, insert the two 3/8 x 1-1/4" bolts. Install washers and lock-nuts on inside of hull.
9. Tighten all nuts and bolts.
10. Reinstall T handle and seat.
11. Slightly tighten the two nylon anti-rattle set screws with 1/8" Allen wrench. Handle should move up and down with a slight drag.
12. Tighten all nuts and bolts after first use. Periodically check for tightness

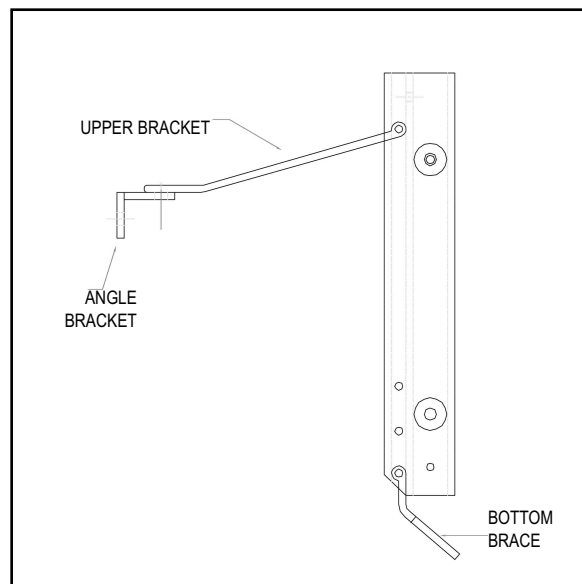

## Maintenance

- If using in salt water, be sure to rinse well after use. Push button and remove T-handle from outside housing. Rinse the button area well to prevent the button from sticking. Push button several times making sure that there are no salt particles left on the button prior to reassembly.
- Periodically check that all fasteners are tight, retighten if necessary.

## How To Use

When sitting backward on the watercraft, reach around the bottom of the SPOT-N-TOW™. With your left hand, using the tip of your index finger, push the button that is in the bottom lock button hole.

Now pull up on the T-handle with your right hand until it locks in the up position.

To lower, use the same process on the top lock button hole. The key is not to put pressure on the T-handle until the button is totally pushed in.

**(When opening the seat storage area it will be easier to raise the T-Handle to its uppermost position, push button again and remove T-handle. After storage area is open, reinstall T-handle)**

## Limited Warranty

Dock Edge + Inc. warrants this product to be free of defects in workmanship and material under normal conditions and for which it is intended for one (1) year from the date of purchase. Any defective product must be returned with a Return Goods Authorization #. A copy of the original sales receipt, must accompany all claims. The freight on the defective goods is the responsibility of the consumer.

Visit [www.dockedge.com](http://www.dockedge.com) for further warranty details.