

**Tools Required**

- 1- 13-MM Socket
- 1- 12-MM Socket
- 1- Ratchet wrench
- 1- Ratchet wrench extension
- 2- 9/16" wrenches
- 2- 3/8" wrenches
- 1- 1/8" Allen wrench
- Marker
- Electric Drill
- 3/8" Drill Bit

**Parts**

- T-handle
- Outside housing
- Top bracket with 1 red dot
- Bottom bracket with 2 red dots
- Bottom brace

**Package of fasteners - Includes -**

- 3 - SS threaded studs
- 6 - SS Black cap nuts
- 2 - 8-MM x 30-MM SS bolts
- 2 - 8-MM SS lock nuts
- 2 - 8-MM SS Washers (for shim)
- 2 - 1-1/4" x 3/8" SS bolts
- 2 - 3/8" SS washers
- 2 - 3/8" SS lock nuts
- 1 - Foam Gasket

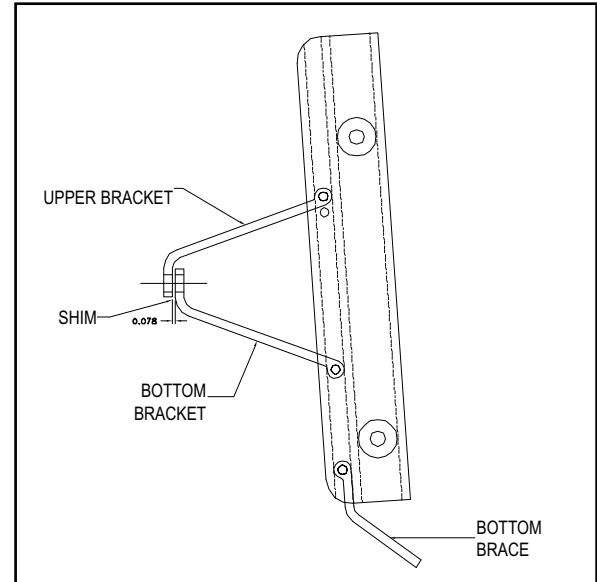

**Preparation & Installation**

1. Remove back seat and storage liner.
2. Unbolt factory ski eye U-clamp with 12-MM socket wrench with extension.
3. Remove U-clamp/ ski hook, nuts and stress plate disregarding the hook and nuts.
4. Remove T-handle by pushing the lock button again when T-handle is in top hole.
5. Assemble SPOT-N-TOW™ brackets in outside housing, with stainless steel studs; the top bracket with one dot goes in top hole. Insert the bottom bracket with the two dots, as shown on drawing (see drawing above). The top bracket goes behind the bottom bracket where the two meet to form a V, matching the red dots.
6. Install the two 8-MM x 30-MM bolts through the two brackets to hold together.
7. Slide assembled unit up from the bottom of grab rail, locating it between the opening of the grab rail.
8. Install the 8-MM bolts, stress plate and nuts into the original ski eyeholes. Install bottom brace to outside housing, position and align, mark hull through the bottom brace for drilling and remove assembly.
9. Drill holes with 3/8" drill bit
10. Reinstall unit, with 8-MM bolts, stress plate, shim washers and nuts. In bottom brace install foam gasket between hull and brace, insert the two 1-1/4" x 16 x 3/8" bolts, washer and locking nuts.
11. Tighten all nuts and bolts.
12. Reinstall T-handle.
13. Slightly tighten the two nylon anti-rattle set screws with the 1/8" Allen wrench. Handle should move up and down with slight drag.
14. Re-install seat.
15. Tighten all nuts and bolts after first use. Periodically check for tightness.

**Note:** When opening the seat storage area it will be easier to raise the T-Handle to its uppermost position, push button again and remove T-handle. After storage area is open, reinstall T-handle

**Maintenance**

- If using in salt water, be sure to rinse well after use. Push button and remove T-handle from outside housing. Rinse the button area well to prevent the button from sticking. Push button several times making sure that there are no salt particles left on the button prior to reassembly.
- Periodically check that all fasteners are tight, retighten if necessary.

**How To Use**

When sitting backward on the watercraft, reach around the bottom of the SPOT-N-TOW™. With your left hand, using the tip of your index finger, push the button that is in the bottom lock button hole.

Now pull up on the T-handle with your right hand until it locks in the up position.

To lower, use the same process on the top lock button hole. The key is not to put pressure on the T-handle until the button is totally pushed in.

**Limited Warranty**

Dock Edge + Inc. warrants this product to be free of defects in workmanship and material under normal conditions and for which it is intended for one (1) year from the date of purchase. Any defective product must be returned with a Return Goods Authorization #. A copy of the original sales receipt, must accompany all claims. The freight on the defective goods is the responsibility of the consumer.

Visit [www.dockedge.com](http://www.dockedge.com) for further warranty details.