

Tools Required

- 2- 13-MM wrenches
- 1- 12-MM wrench
- 2- 9/16" wrenches
- 2- 3/8" wrenches
- 1- 1/8" Allen wrench
- Marker
- Electric Drill
- 3/8" Drill Bit

Parts

- T-handle
- Outside housing
- Top bracket with 1 red dot assembled to angle
- Bottom brace preassembled in Outside housing

Package of fasteners - Includes -

- 1 - SS threaded stud
- 2 - SS Black cap nuts
- 2 - 8-MM SS lock nuts
- 2 - 1-1/4" x 3/8" SS bolts
- 2 - 3/8" SS washers
- 2 - 3/8" SS lock nuts
- 1 - Foam Gasket

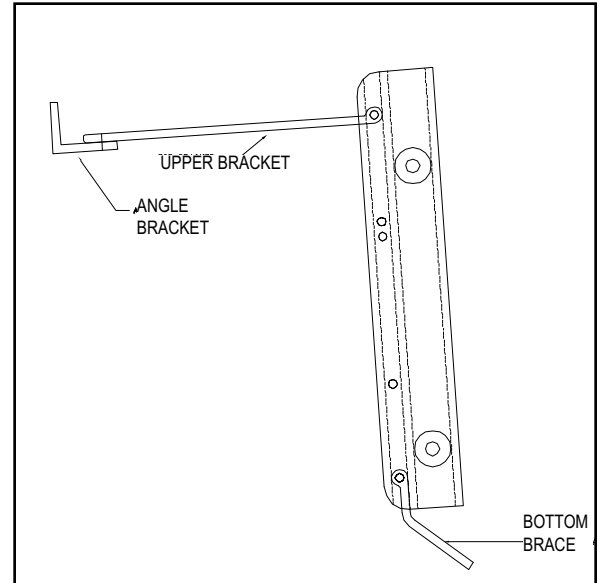

Preparation & Installation

1. Remove back seat and storage liner.
2. Unbolt factory ski eye U-clamp with 12-MM wrench.
3. Remove ski-eye. Retain the 2 stress plates for use later.
Caution should be taken not to drop the factory stress plate that is located on the inside of the hull.
4. Install the top bracket with the red dot down (angle up) with the 8-MM bolts that are pre-assembled in the bracket into the original ski-eye holes. Use both factory stress plates, washer and nuts that are provided on the inside of the hull.
5. On this model the SPOT-N-TOW™ goes on the outside of the rear grab handles. Slide the outside housing onto the Top Bracket "ears" from the top. Line up the holes in the Top Bracket "ears" and the outside housing and place the threaded stud through these holes.
6. Push the pre-assembled bottom brace in until it makes contact with the hull. (holes should be right below the warning label). Mark holes for drilling.
7. Remove pylon and drill 3/8" holes for bottom brace. Be sure to drill just through the fiberglass.
8. Re-install unit, install bottom brace with foam gasket between hull and brace, insert the two 3/8" x 1-1/4" bolts, install washers and nuts on inside of hull.
9. Tighten all nuts and bolts.
10. Slightly tighten the two nylon anti-rattle set screws with the 1/8" Allen wrench. Handle should move up and down with slight drag.
11. Tighten all nuts and bolts after first use. Periodically check for tightness.

Maintenance

- If using in salt water, be sure to rinse well after use. Push button and remove T-handle from outside housing. Rinse the button area well to prevent the button from sticking. Push button several times making sure that there are no salt particles left on the button prior to reassembly.
- Periodically check that all fasteners are tight, retighten if necessary.

How To Use

When sitting backward on the watercraft, reach around the bottom of the SPOT-N-TOW™. With your left hand, using the tip of your index finger, push the button that is in the bottom lock button hole.

Now pull up on the T-handle with your right hand until it locks in the up position.

To lower, use the same process on the top lock button hole. The key is not to put pressure on the T-handle until the button is totally pushed in.

Limited Warranty

Dock Edge + Inc. warrants this product to be free of defects in workmanship and material under normal conditions and for which it is intended for one (1) year from the date of purchase. Any defective product must be returned with a Return Goods Authorization #. A copy of the original sales receipt, must accompany all claims. The freight on the defective goods is the responsibility of the consumer.

Visit www.dockedge.com for further warranty details.